

atoM Compact
Membrane
Bioreactor

The Most Compact
Sewage Recycle System

The latest offering from Thermax Water and Waste Solutions, atoM is a unique modularised MBR product to treat sewage efficiently; contributing to the circular economy model of reduce, reuse and recycle. This compact package consists of processes involving biological degradation of organic load and nutrients integrated with membrane filtration. Further, it eliminates nitrogen and phosphorus, consistently achieving good quality of treated sewage which is suitable for recycle and reuse.

Membrane bio-reactor is the combination of activated sludge process with membrane filtration system. This package includes screening, oil & grease removal, equalisation, fine screening, anoxic zone, aeration and membrane filtration.

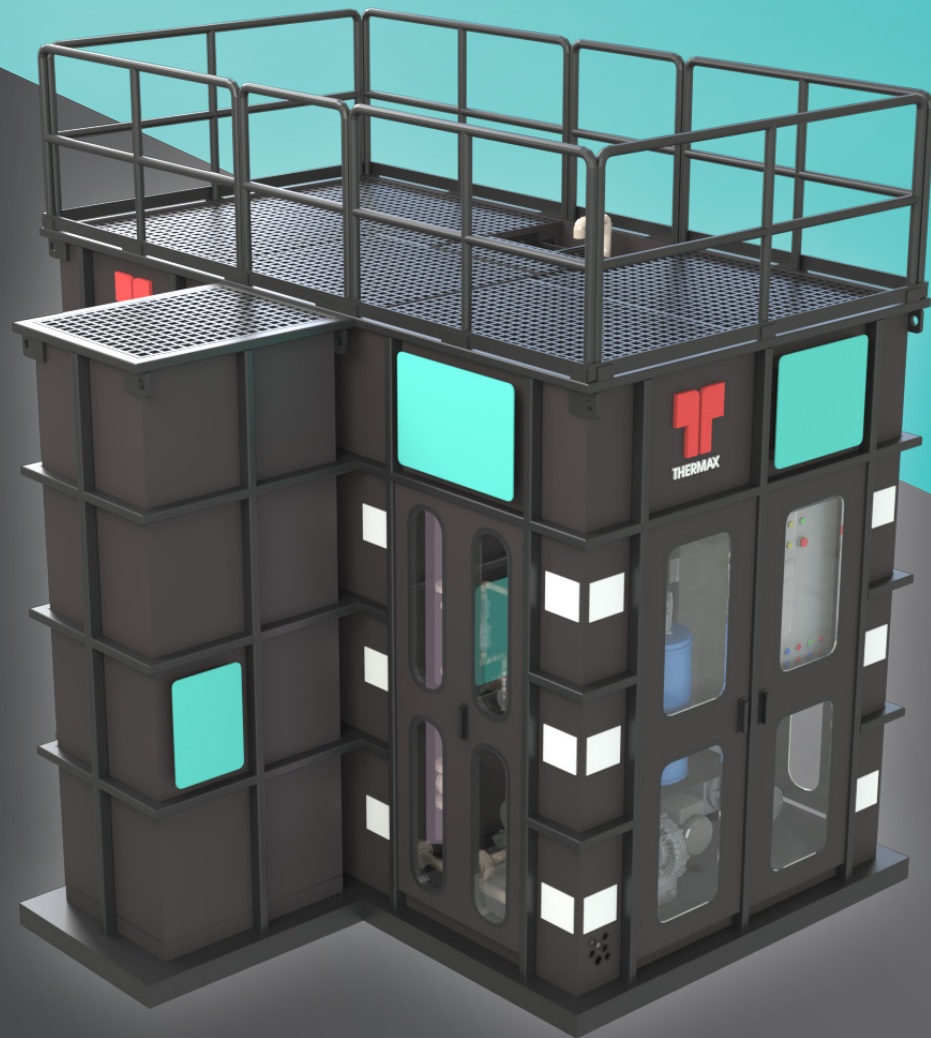

Product Capacities 10, 20, 30 and 50 KLD

 Completely Modularised

 Most Compact Sewage Recycle Plant

 Completely Automated Operations

 Adherence to Safety Norms

 Complies with Latest PCB Norms

 55% Installation Area Reduction

 40% Lesser Height For Basement Installation Single Basement Installation

 Consistent High Quality Treated Water

 Most Silent Plant

 Aesthetically New Age Design

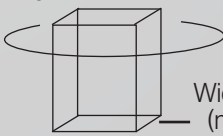
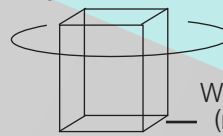
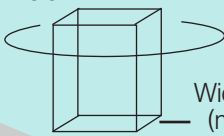
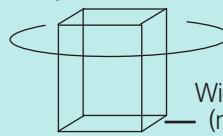
PRODUCT SIZE 10 KLD	PRODUCT SIZE 20 KLD	PRODUCT SIZE 30 KLD	PRODUCT SIZE 50 KLD
Area (m ²) 6	Area (m ²) 10	Area (m ²) 13.5	Area (m ²) 21.6
			
Length (m) 3.4	Length (m) 5.6	Length (m) 7.5	Length (m) 12
Width (m) 1.8	Width (m) 1.8	Width (m) 1.8	Width (m) 1.8

Product height is 2.5 m for basement installations

Connected Service Offerings

Thermax has first-of-a-kind series of four value added operations & maintenance services for effective and efficient plant management:

Connect



An basic assessment of the plants by Thermax experts

Care



A detailed assesement with check-up visits

Commitment



Non-comprehensive operations and maintenance

Complete



Comprehensive operations and maintenance

Market Segments



Housing and Residential Complexes



Hotels



Hospitals



Educational Institutes



Commercial complexes & IT Parks

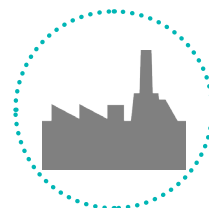

Industries



THERMAX

Sustainable Solutions in Energy & Environment

Registered Office

Thermax Limited
D-13, MIDC Industrial Area, R D Aga Road,
Chinchwad, Pune 411019, India
enquiry@thermaxglobal.com
Customer Care: 1800-209-0115

Corporate Office

Thermax House
14 Mumbai-Pune Road,
Wakdevadi, Pune 411 003
+91-20-66051200/25542122
+91-20-25541226

graphicjampm@gmail.com

www.thermaxglobal.com

thermaxglobal

thermax_global

thermaxlimited

thermaxglobal

thermaxmedia

This brochure presents only some of our products and we reserve the right to amend any product details without notice.
The photographs used in the brochure are indicative and may not match the actual plant © 2020 Thermax limited. All rights reserved.

